

# Sandeel

Design: Peter Buchan-Symons and Neil Banas

Diagrams: Peter Buchan-Symons

Sandeels or sand lances (family *Ammodytidae*) are slender, silvery fish that are a crucial food source for many seabirds, whales, and bigger fish like cod and salmon. They like to hide in the sand for much of the year.

In the North Sea they have been getting smaller as the zooplankton that they eat decline, and the effects are being felt through the entire food web.

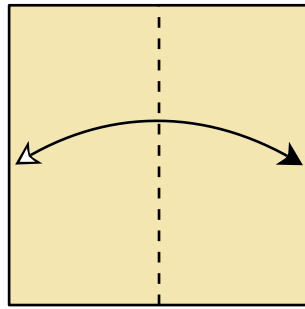

1. Fold in half vertically and unfold.

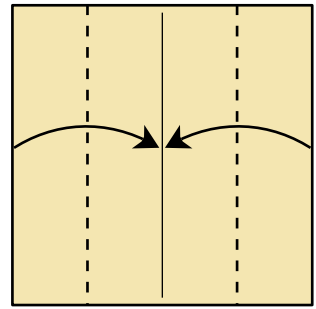

2. Fold the raw edges to the crease you just made.

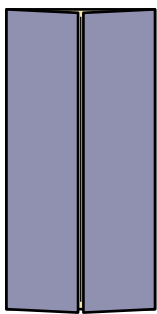

3. Turn the paper over.

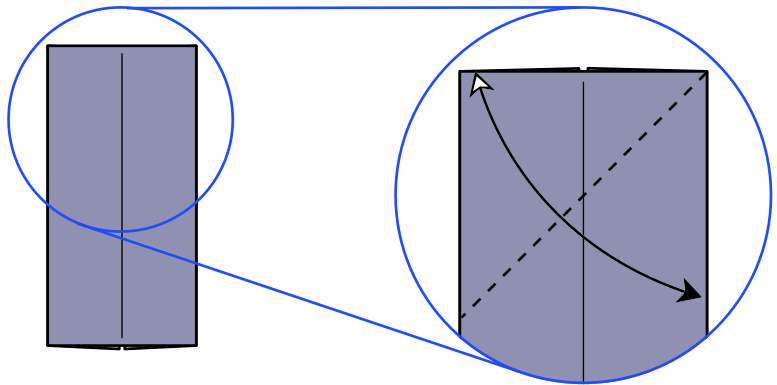

4. Fold the top edge to the right edge and unfold.

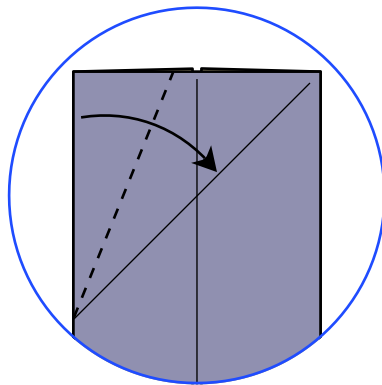

5. Fold the corner to the crease you just made.

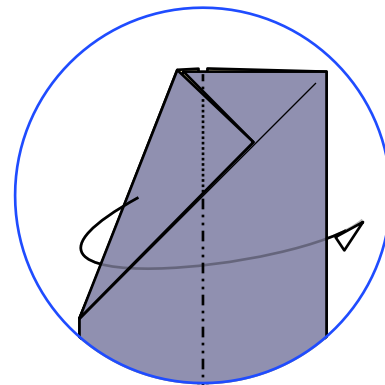

6. Mountain-fold the left half behind the right side.

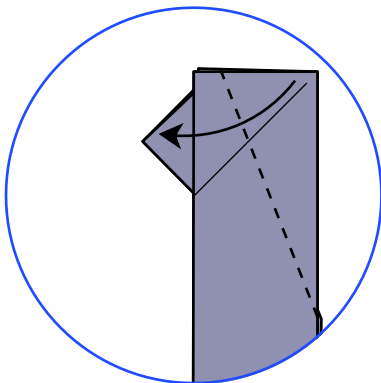

7. Fold the corner to match the one behind.

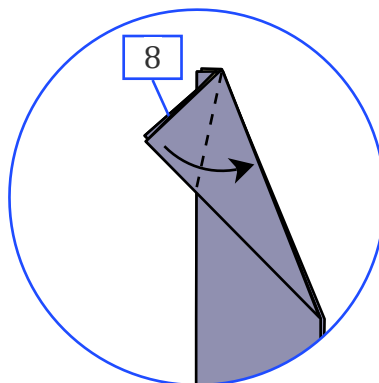

8. Fold the corner to the folded edge. Repeat behind.

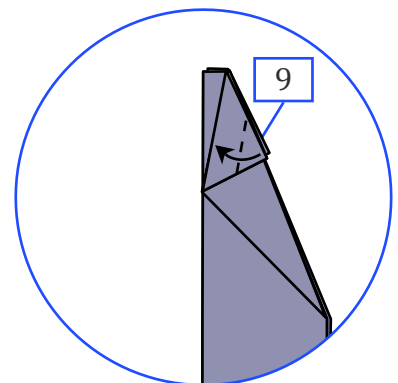

9. Fold the corner to the folded edge. Repeat behind.

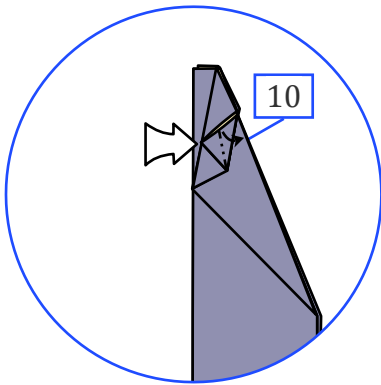

**10.** Squash-fold the flap. Repeat behind.

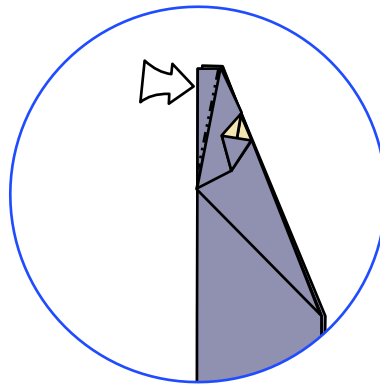

**11.** Reverse-fold the narrow flap. The fold-line aligns with the folded edge.

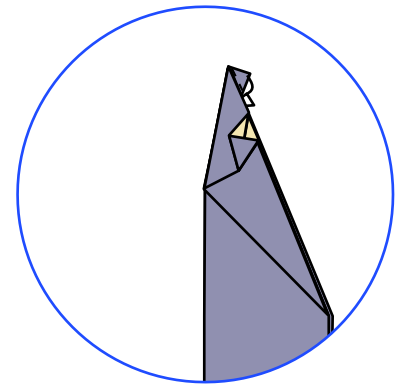

**12.** Tuck the very small corner underneath the near layer.

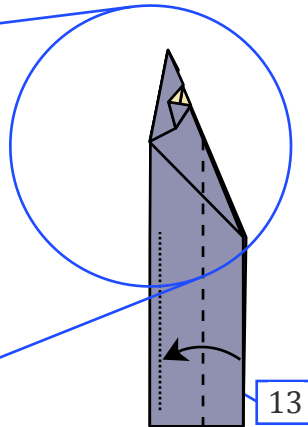
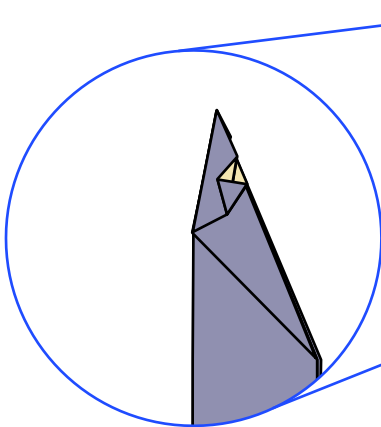

**13.** Fold the edge nearly to the spine. Repeat behind.

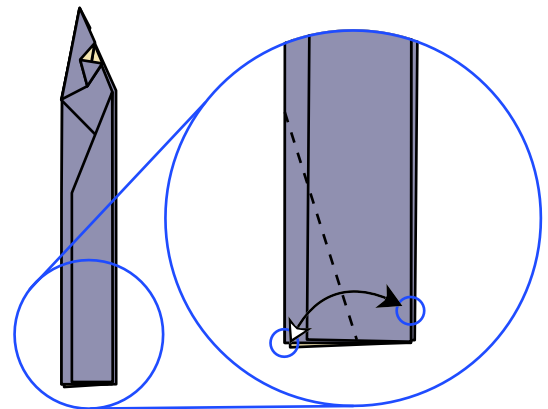

**14.** Fold the bottom left corner to the folded edge and unfold.

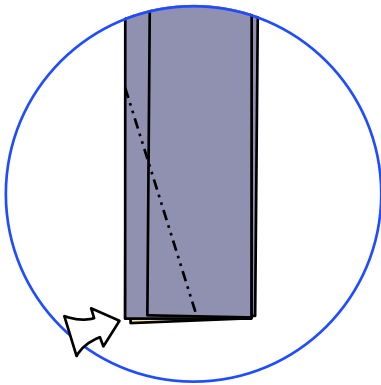

**15.** Reverse-fold using the creases you just made.

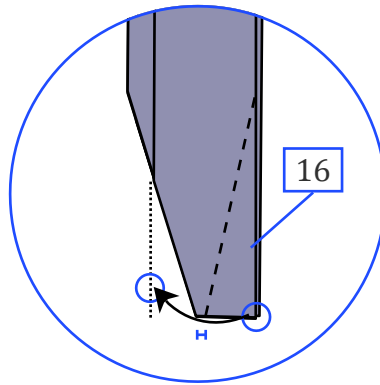

**16.** Fold the bottom right corner to the left. Note the slight gap along the bottom edge. Repeat behind.

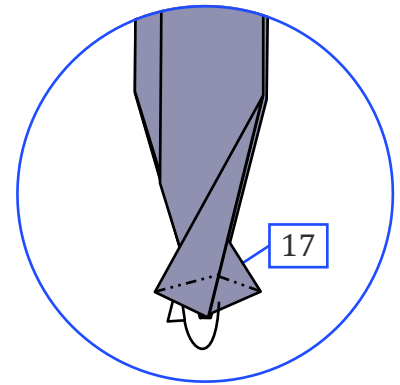

**17.** Fold the edge underneath; spread the excess paper to create a reflex angle. Repeat behind.

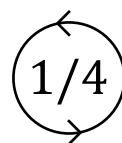
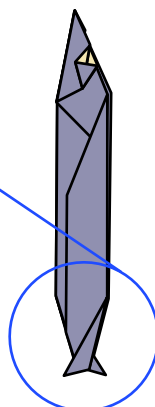
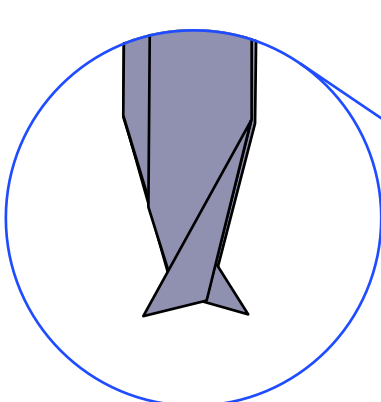

**18.** Rotate the model.

